

CLOSE COUPLED BRONZE CENTRIFUGAL PUMP

PIPE SIZE INLET 1 1/4, OUTLET 1



FEATURES

- Rugged Bronze Construction
- A Standard in the Marine Air Conditioning Industry
- Extremely Quiet Operation
- O-Ring Housing seal eliminates gasket problems
- Teflon Barrier Seal to protect motor bearings
- Handles Contaminated Liquids
- Discharge port orientation flexibility-8 positions
- Mechanical Seal - Carbon/Ceramic
 - Buna - standard
 - Viton (S10) optional
 - Teflon (S11) optional
- Pump Heads mount to standard footed Nema 56J Jet Pump Motors
- Shafts: 416 Stainless, Monel, or 316 Passivated Stainless
- Multiple motor options available
- For Industrial Version - see Model 700 series

LIQUIDS

The special pump alloys used provide corrosion resistance to many liquids including water, water solutions, and a wide range of commercial chemicals. Questions as to the chemical compatibility of special liquids should be referred to the factory.

Viscous liquids with a maximum viscosity of 2000 Saybolt Seconds Universal can be pumped. However, when pumping viscous liquids as compared with water, a reduction in flow and pressure occurs and the required horsepower rate increases.

Liquids heavier than water require additional

*Viton® is a registered trademark of DuPont Dow Elastomers. Viton® or equivalent FKM will be used.
Teflon® is a registered trademark of DuPont. Teflon® or equivalent PTFE will be used.

PERFORMANCE

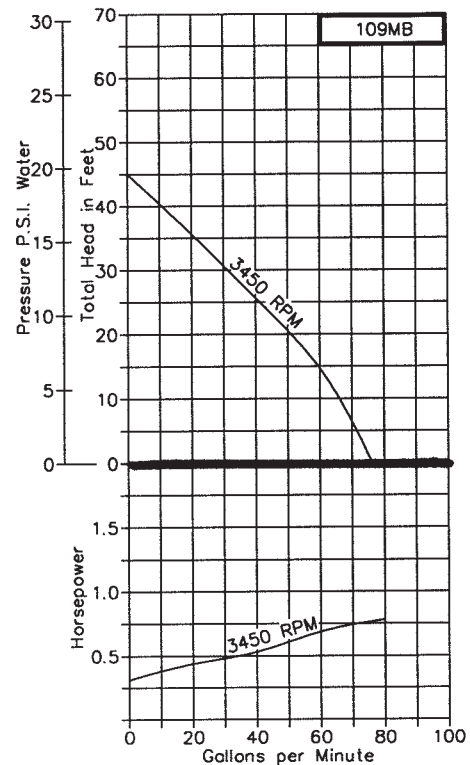

horsepower in direct proportion to the increase in specific gravity. Liquids contaminated with small solids or abrasives can be handled, but a reduction in mechanical seal life must be expected.

CHARACTERISTICS

This close-coupled pump uses a standard NEMA C-Flange Jet Pump Motor with weld-on base and threaded shaft end to accept the pump impeller. Single phase motors are non-reversible and are wired for the proper pump rotation which is counter-clockwise looking at the inlet end of the pump. (See the dimensional drawing on back.) Three phase motors must be checked out for proper rotation when the pump is installed. Interchanging of any 2 wires in a 3-phase system will reverse motor rotation.

The pump uses a mechanical type shaft seal with a Buna N rubber element. It is suitable for water, oils, and some mild solvents and it is limited to 212°F and 75 P.S.I. Viton(R)* seals and Teflon(R)* seals are available for severe solvents and difficult chemicals.

CLOSE COUPLED BRONZE CENTRIFUGAL PUMP

EXPLODED VIEW & PARTS LIST

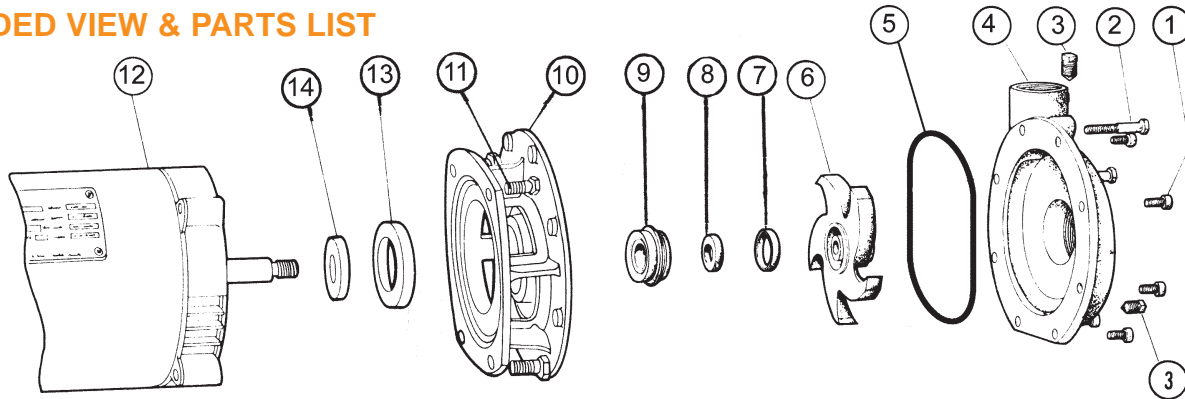

Pump No.	1	2	3	4	5	6	7, 8, 9	10	11	12	13	14	15*	16*	Repair Kit**
	Screw	Screw	Pipe Plug	Body	O Ring	Impeller	Seal Assembly	Adapter	Screw	Motor	Insert	Barrier	Set Screw	Shim	
	5 req'd	3 req'd	2 req'd	1 req'd	1 req'd	1 req'd	1 req'd	1 req'd	4 req'd	1 req'd	1 req'd	1 req'd	1 req'd		
109MB	9783-04	9783-14	7687	5266	9797-157	6297	32155	5251	5411	----	6832	6683	----	6025	10721
109MBP	9783-04	9783-14	5395	5266	9797-157	7196	32155	5251	5411	----	6832	6683	9849	6025	11065
109MB-S10	9783-04	9783-14	5395	5266	9797-157	6297	32210	5251	5411	----	6832	6683	----	6025	12274
109MB-S11	9783-04	9783-14	5395	5266	9355-157S	6297	32211	6300	5411	----	6832	6683	----	6025	12276

Notes: * Set Screw for three phase motor (not shown), Impeller shim (not shown)
** Repair Kit includes items 5,6,7,8,9,14,15,16 (and 5307 gasket for older models)

DIMENSIONS

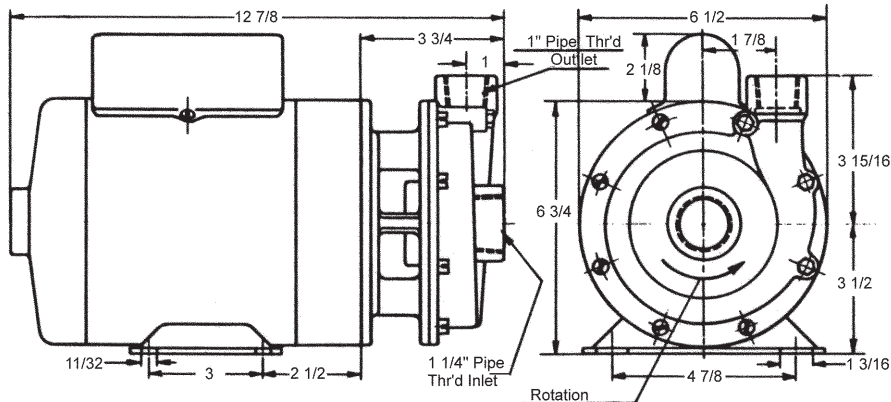

(continued from front)

These centrifugal pumps are not self-priming. They must be installed below the liquid level so that the liquid flows to the pump by gravity (flooded suction). However, if a foot valve is used at the beginning of the suction line and all air is bled from the pump by manual priming, the pump will lift on the suction side up to 15 feet. Such a system relies entirely on a non-leaking foot valve for starting capability.

The flow of a centrifugal pump can be conveniently controlled by a throttling valve in the discharge line without the need for a relief valve. In centrifugal pumps, the horsepower demand will decrease as the pressure increases. Maximum horsepower occurs with a wide open discharge.

MOTOR OPTIONS

Pump No.	HP	SF	Enclosure	Phase	Voltage	Shaft	Motor
						Construction	Item 12
109MB-J19	1/2	1.65	ODP	single	115 / 230	416	5860
109MBP-J57	1/2	1.60	ODP	three	230 / 460	416	6998
109MB-J20	1/2	1.65	TEFC	single	115 / 230	416	7976
109MB-01J26	1/2	1.65	ODP	single	115 / 230	monel	32332
109MBP-01J58	1/2	1.00	TEFC	three	208 230 / 460	monel	33035
109MB-J24	1/2	1.65	ODP	single	115 / 230	316 passivated	3031
109MB-J89	1/2	1.00	TENV	DC	12V	416	2386
109MBP-M58	3/4	1.15	TEFC	three	230 / 460	416	7967
109MBP-M57	3/4	1.50	ODP	three	50/60HZ 208-220/440	416	6999