

# DUCTILE IRON CLOSED COUPLED ROTARY GEAR PUMPS

## MODEL C9941B1 - 3/4" PORTS



### FEATURES

- Ductile Iron construction with steel shafts
- Stainless steel helical gears for quiet operation
- Mechanical seal
- Self lubricating carbon bearings
- O-ring seal for maximum leak protection
- Durable temperature-resistant paint finish
- Easy field assembly to C-face motors
- Compact dimensions

### GENERAL DESCRIPTION

Tailored specifically for wear resistance and long life in coolant filtration service. Designed to handle a wide range of water-based and synthetic machine tool coolants, at moderate temperatures to 180° F, at pressures up to 100 psi and at shaft speeds to 1750 RPM. Shafts are hardened steel. Gears are 416 stainless steel. Rugged ductile iron housings incorporate body/gear lubrication grooves. High grade carbon-graphite bearings are used. The shaft seal is a bellow style mechanical seal with Viton® elastomer bellows and o-ring and with carbon and ceramic wear faces. As with all external gear rotary pumps which operate based upon close running clearances, the presence of solid particles and abrasives can lead to premature wear and damage. Use suction screens or start-up strainers when necessary.

### DRIVE ARRANGEMENT

These close-coupled pumps mount directly to a full range of NEMA and IEC C-face motors by means of a suitable adapter bracket. The pump drive shaft is connected to the motor shaft by flexible coupling. Complete pump and motor units are available.

### SUCTION LIFT

If possible, place the pump at an elevation below the liquid source. However, since these positive displacement external gear

## PERFORMANCE

Water 70° F

1725 RPM					Pump, Adapter & ODP Motor* No.	
PSI	GPM	HP Req'd	HP Motor	Motor Frame	Single Phase	Three Phase
0	10.5	0.5	1/2	56C	C9941B1H-J45	C9941B1H-J95
10	10.4	0.63	3/4	56C	C9941B1H-M37R	C9941B1H-M95
20	10.3	0.75	3/4	56C	C9941B1H-M37R	C9941B1H-M95
30	10.2	0.83	1	56C	C9941B1H-N26	C9941B1H-N95
40	10.1	0.90	1	56C	C9941B1H-N26	C9941B1H-N95
50	10.0	1.00	1 1/2	145TC	C9941B1J-T45	C9941B1J-T95

\*TEFC motors available

1150 RPM					Pump, Adapter & ODP Motor* No.	
PSI	GPM	HP Req'd	HP Motor	Motor Frame	Single Phase	Three Phase
0	6.8	0.24	1/2	56C	C9941B1H-J46	C9941B1H-J96
10	6.7	0.27	1/2	56C	C9941B1H-J46	C9941B1H-J96
20	6.6	0.29	1/2	56C	C9941B1H-J46	C9941B1H-J96
30	6.5	0.36	1/2	56C	C9941B1H-J46	C9941B1H-J96
40	6.4	0.43	1/2	56C	C9941B1H-J46	C9941B1H-J96
50	6.3	0.50	3/4	56C	C9941B1H-M46	C9941B1H-M96

\*TEFC motors available

pumps will generate 23" HG lift, this is not a requirement. As a general rule, place the pump as close to the liquid source as possible. For a first start-up, the pump should be primed to avoid dry running. Minimum size of the suction pipe is the size of the pump inlet port. For longer suction lines (over 3 feet), the pipe size should be at least one size or two sizes larger than the pump inlet port.

### ROTATION AND RELIEF VALVE

Given the body/gear face lubrication slots, these pumps are unidirectional. The standard pump is set up for normal rotation (clockwise when viewing the pump from the shaft end). Contact the factory if opposite rotation is required.

C994R1B1 is equipped with an integrated relief valve set up for internal bypassing. The relief valve is not intended to be a metering or flow control device. Its purpose is to function as a discharge pressure relief to guard against intermittent down stream system restrictions. Overheating can occur within 5 to 10 minutes if the discharge line is completely shut off. The relief valve is located on the discharge side of the pump. The pressure relief setting is not set at the factory. To increase pressure, turn the relief valve adjusting screw in a clockwise direction.

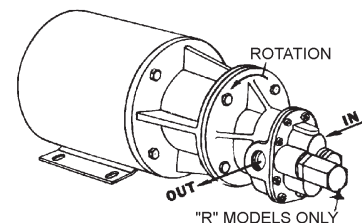

# DUCTILE IRON CLOSED COUPLED ROTARY GEAR PUMPS

## EXPLODED VIEW & PARTS LIST

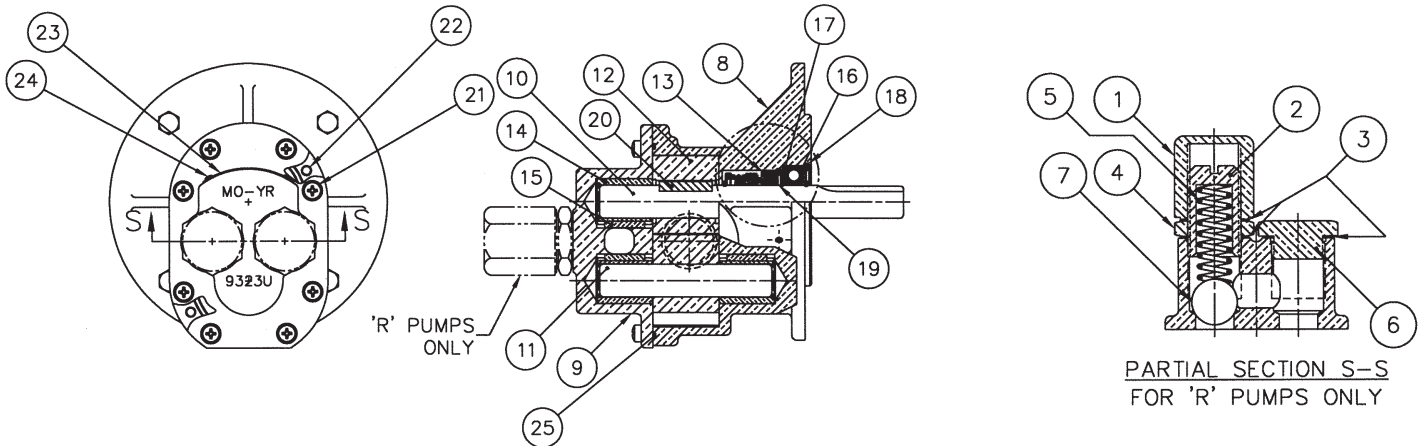

	1	2	3	4	5	6	7	8	9	10	11	12	13	14	15
	Bypass Nut	Adjust. Screw	Fiber Washer	Locknut	Spring	Plugnut	Ball	Body	Cover	Drive Shaft	Idle Gear Assy.	Drive Gear	Mech Seal	Bearing Carbon	Bearing Pin
Pump No.	Qty. 1	Qty. 1	Qty. 3	Qty. 1	Qty. 1	Qty. 1	Qty. 1	Qty. 1	Qty. 1	Qty. 1	Qty. 1	Qty. 1	Qty. 1	Qty. 3	Qty. 3
C9941B1	N/A	N/A	N/A	N/A	N/A	N/A	N/A	9320UE4N	9322UN5N	2785	33127	2888	33109	2688	2687
C94R1B1	5204	5200	6964	5209	5207	5205	5206	9320UE4N	9323UN5B	2785	33127	2888	33109	2688	2687

	16	17	18	19	20	21	22	23	24	25	26
	Bearing Ball	Ret. Ring	Ret. Ring	Ret. Ring	Key	Screw	Dowel Pin	Tag	Stick Screw	O-Ring	Adapter Kits
Pump No.	Qty. 1	Qty. 3	Qty. 1	Qty. 1	Qty. 1	Qty. 8	Qty. 2	Qty. 1	Qty. 2	Qty. 1	See Chart
C9941B1	2461	5382	5464	5374	6567	5385	8885	9344	9345	9797-041	
C994R1B1	2461	5382	5464	5374	6567	5385	8885	9344	9345	9797-041	

Adapter Kit	Part Number	Description
H	11299C	56C Frame
J	11300C	143TC/145TC
G	11380	IEC 71
T	11386	IEC 80

Repair Kit, Part Number 12216, contains items 10-20 & 25.

## DIMENSIONS

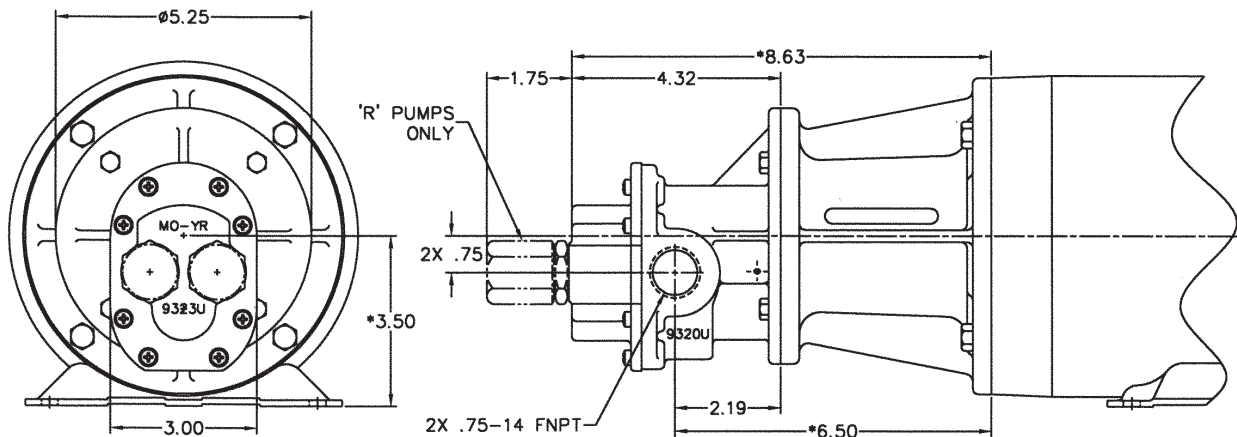

\*THESE DIMENSIONS ARE SPECIFIC TO A 56C OR 143TC/145TC FRAME MOTOR.

Specifications are subject to change without notice..

\*Viton® or equivalent FKM will be used. Viton® is a trademark of DuPont Dow Elastomers.